



Assent™ Audiometric Booth

LEVEL WALK-IN SERIES | EASY ACCESS | RAPID INSTALLATION



Accutone2
ANY SIZE • ANY SHAPE • ANY COLOR

The **Accutone2® Assent™ Series** is a single or multiple occupancy room constructed of 4" thick Noise-Lock® V panels, complete with carpeted multi-layered, acoustic floor system, space-saver roof mounted ventilation, recessed electrical, Noise-Lock doors and double-glazed windows, audiometric jack panels acoustically matched, and shipped ready for field assembly.

- Low-Profile entry
- ADA Compliant
- NIC 47
- NIC 49 with 1" Enhancement Package

ADDITIONAL INFORMATION >>



Typical Plan

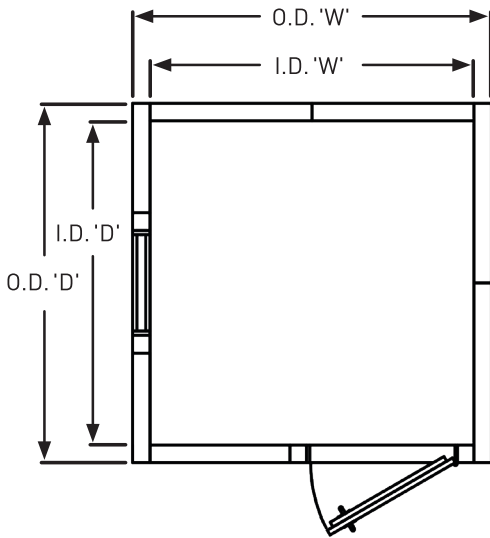

Model No.	Inside Dimension ft-in x ft-in x ft-in					Outside Dimension ft-in x ft-in x ft-in					Weight (lbs)
	W	x	D	x	H	W	x	D	x	H	
40a-1	3-6	x	2-10	x	6-6	4-2	x	3-6	x	7-7	1,133
40a-2	4-4	x	3-6	x	6-6	5-0	x	4-2	x	7-7	1,441
40a-2.5	6-2	x	3-6	x	6-6	6-10	x	4-2	x	7-7	1,818
40a-3	6-8	x	3-6	x	6-6	7-4	x	4-2	x	7-7	1,921
40a-4	7-0	x	4-8	x	6-6	7-8	x	5-4	x	7-7	2,315
40a-5	6-2	x	6-2	x	6-6	6-10	x	6-10	x	7-7	2,516
40a-5.5	7-6	x	6-4	x	6-6	8-2	x	7-0	x	7-7	2,913
40a-6	7-0	x	7-0	x	6-6	7-8	x	7-8	x	7-7	2,966
40a-7	7-6	x	7-0	x	6-6	8-2	x	7-8	x	7-7	3,106
40a-7.5	8-4	x	6-4	x	6-6	9-0	x	7-0	x	7-7	3,134
40a-8	8-8	x	7-0	x	6-6	9-4	x	7-8	x	7-7	3,432
40a-9	9-10	x	7-0	x	6-6	10-6	x	7-8	x	7-7	3,757
40a-10	8-8	x	8-2	x	6-6	9-4	x	8-10	x	7-7	3,798
40a-11	8-6	x	8-6	x	6-6	9-2	x	9-2	x	7-7	3,851
40a-12	9-10	x	8-2	x	6-6	10-6	x	8-10	x	7-7	4,152
40a-13	9-10	x	9-4	x	6-6	10-6	x	10-0	x	7-7	4,547
40a-13.5	11-2	x	8-8	x	6-6	11-10	x	9-4	x	7-7	4,740
40a-14	9-10	x	10-6	x	6-6	10-6	x	11-2	x	7-7	4,942

ADDITIONAL INFORMATION >>

Assent™ Audiometric Booth



Total Estimated Design Weight:

See table on page 2

Panel Construction:

Noise-Lock® V (walls) and Noise-Lock® VI (ceiling)

Panel Size:

Maximum panel size to be determined by customer for adequate site access

Interior Surfaces:

22ga. galvanized perforated steel

Exterior Surfaces:

14ga. galvanized solid steel

Floor Interior Surface:

11ga. hot rolled steel

Finish:

Textured powder coated

Door:

(1) 2'-9" wide x 6'-1½" high clear opening cam-lift splitframe with push plate and pull handles

Note:

- Dimensions locating door are shown to the clear opening
- Noise-Lock® STC-51

Window:

(1) 2'-6" wide x 2'-10" high aluminum frame double glazed with ¼" thick laminated safety glass (width reduced on smaller models)

Booth Vibration Isolation:

Low profile, multi-layered, acoustic floor system

Electrical:

- 120V recessed LED light fixture
- 120V toggle switch for fans and lights
- 120V duplex receptacle

Note:

- Customer to provide 110V, 60Hz, 20 amp power to roof mounted quad receptacle power cord
- All electrical is wired per national electric code
- Booth is factory UL certified and labeled
- (Lot) boxes, connectors, etc. as required for complete installation

Audiometric Jack Panel Comprised of:

- (12) Switchcraft three-wire phone-type jacks
- (2) USB ports
- (1) 2" ID pass-through hole with cover

Booth Options:

Ventilation:

Integrated SpaceSaver exhaust/inlet air ceiling silencer panels and 120V, 60Hz, 14w fans or HVAC connection collars to connect to building system

Available Colors:

- | | |
|----------------|------------------|
| ■ Khaki Shade | ■ Kinetic Khaki |
| ■ Polar Blue | ■ Colony Blue |
| ■ Limoge Cream | ■ Cinnamon Stick |
| ■ Celedon | ■ Jade Market |
| ■ First Star | ■ Silver Plate |
| ■ Pure White | ■ Gray Primer |

Floor Covering:

Nylon carpet to match paint color selection with 3/8" thick underlayment and 2-1/2" H black cove base molding included

Site Requirements:

- Customer to provide a finished floor which is within +/- ¼" of level in 10 non-cumulative feet
- 4" minimum clearance is required between the exterior of testing booth and host facility walls/ceiling

ADDITIONAL INFORMATION >>>

Doors:

- Noise-Lock® double-glazed windows in door
 - 12" x 12" View Port
 - 16" x 24" Half Glass
 - 20" x 54" Full Glass
- Additional & oversized doors including double leaf
- Wood veneered door finishes
- Mortised type, lever handle, recessed key locks
- Door closers



Optional Equipment:

- One-way Noise-Lock® glass
- RF & electromagnetic shielding
- Special jack-panels
- Pass-throughs
- Fire-rated outer walls and doors



Standard Enhancement Packages:

- Enhancement packages available with choice of fabric & liner colors
- Paneling & carpeting in 5 colors
- Absorptive & aesthetic fabric top paneling
- Space-enhancing chair-rail
- Edge-smoothing corner panels

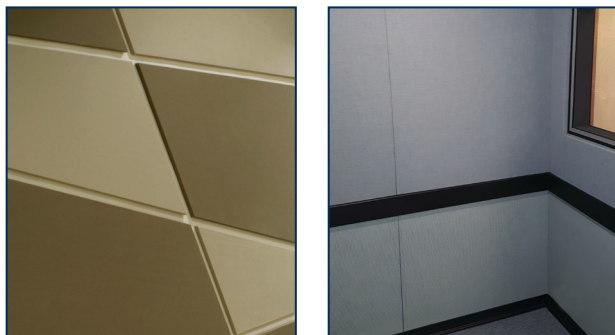

Exterior Enhancement Packages:

- Exterior enhancement packages available with WoodTrends® by Sound Seal
- Aesthetically pleasing finishes that show off the beauty of real wood
- Available in a variety of popular as well as exotic wood veneer species (additional veneer options available upon request)

